

SPECIFICATIONS:

MODEL NUMBER: 8000-953-238

PUMP DESIGN: Positive Displacement 3 Chamber Diaphragm Pump

CHECK VALVE: (2-Way Op.) Prevents Reverse Flow & 6 Ft. Head Forward Flow

CAM: 3.0 Degree

MOTOR: Permanent Magnet, P/N 11-127-10

VOLTAGE: 24 VDC Nominal

PRESSURE SWITCH: Adjustable Shut-Off (Range 80-100 PSI)

Factory Set @100 PSI, Turn On 85 PSI ±5 PSI

LIQUID TEMPERATURE: 180 Degrees Fahrenheit (82 Degrees Centigrade) Max.

PRIME: Self-Priming Up To 10 Ft. Vertical,
Max. Inlet Pressure 30 PSI (2.1 Bar)

PORTS: 3/8"-18 NPT Female

MATERIAL OF CONSTRUCTION:

PLASTICS- Nylon

VALVES- EPDM

DIAPHRAGM- Santoprene

FASTENERS- Zinc or Cad Plated Steel

NET WEIGHT: 4.7 Lbs (2.13 Kg)

DUTY CYCLE: Intermittent (See Temperature Rise Chart)

TYPICAL APPLICATIONS: Industrial Spraying

DIMENSIONS:

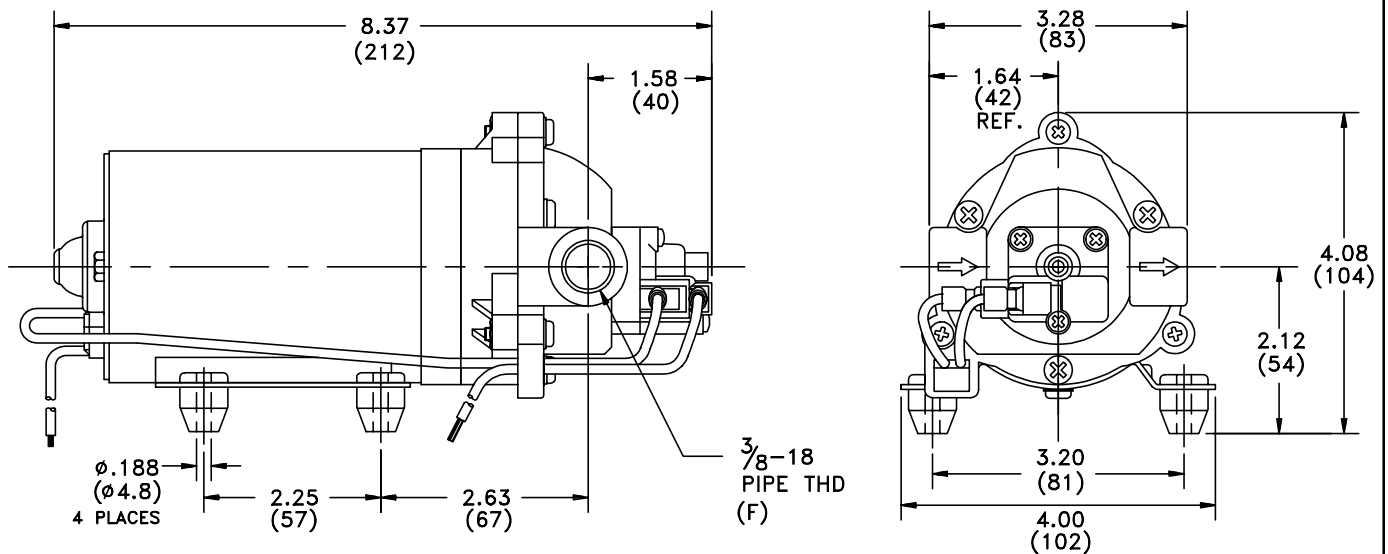

TEMPERATURE RISE

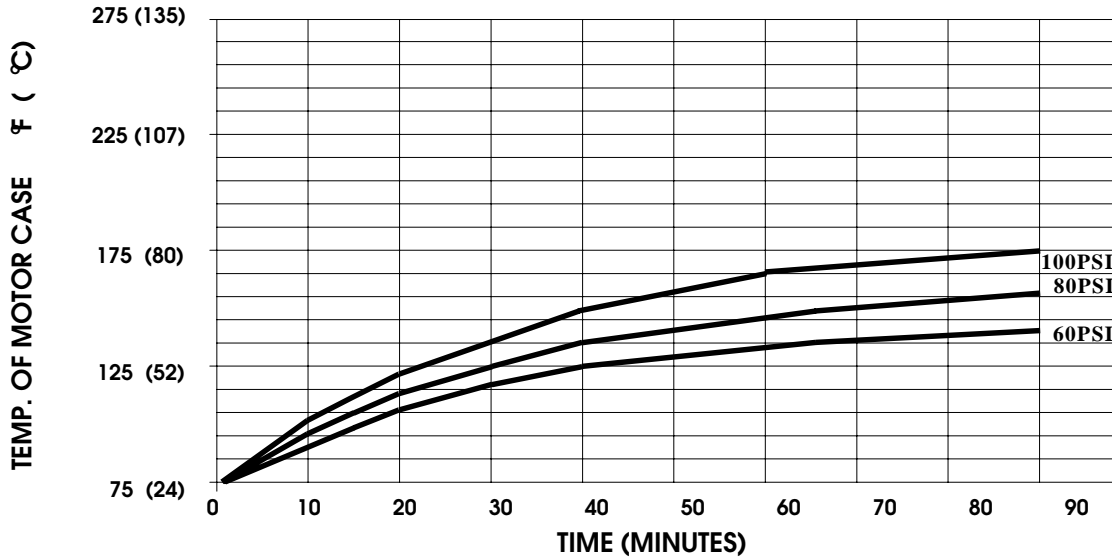

THIS GRAPH IS FOR USE AS A DESIGN GUIDE. IT IS BASED ON RUNNING CONTINUOUSLY WITH AN AMBIENT TEMPERATURE OF 70° F IN STILL AIR.

TYPICAL PERFORMANCE

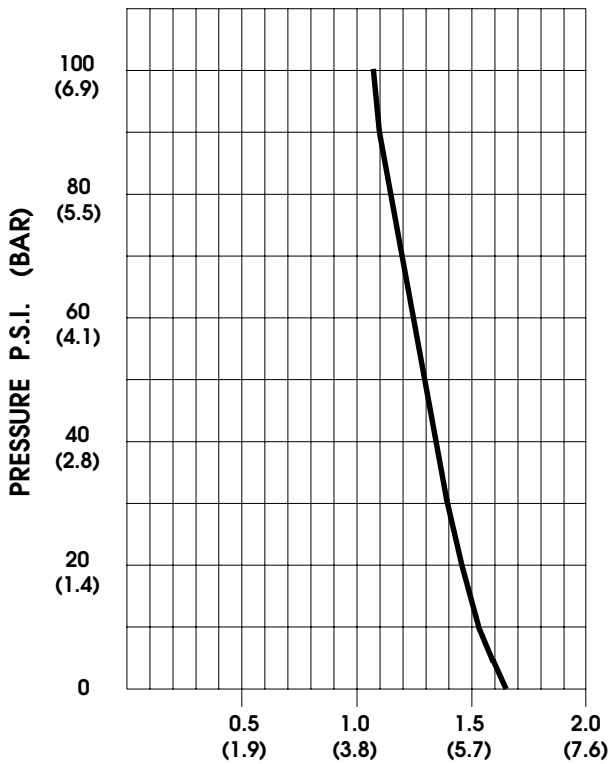

PRESSURE (PSI)	FLOW (GPM/LIT)	RPM MIN/MAX	CURRENT (AMPS)	VOLTAGE (VOLTS)
OPEN	1.62/6.1	2310/2320	1.6	24VDC
10	1.52/5.8	2280/2285	2.0	"
20	1.45/5.5	2240/2250	2.4	"
30	1.39/5.3	2200/2220	2.7	"
40	1.34/5.1	2170/2195	3.0	"
50	1.29/4.9	2135/2170	3.3	"
60	1.24/4.7	2105/2150	3.6	"
70	1.19/4.5	2075/2115	3.9	"
80	1.15/4.4	2040/2090	4.2	"
90	1.11/4.2	2010/2060	4.4	"
100	1.07/4.0	1965/2005	4.7	"

FLOW - GALLONS PER MINUTE (LITERS PER MINUTE)

*-SPECIFICATIONS SUBJECT TO CHANGE WITHOUT NOTICE.
-ALL DATA BASED ON TESTING WITH WATER.*